

CATIA V5

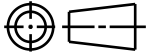

Revision Level		Revision Record	Changed	Date	Approved	Date
Drawing	Part					
02.1	-	SEE ECN# 014888	CTF	01/28/2019	KAC	01/28/2019

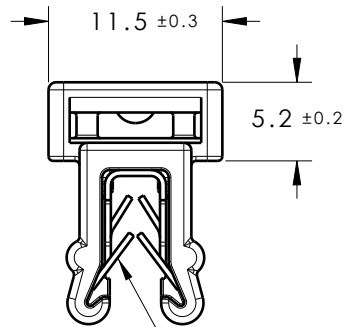
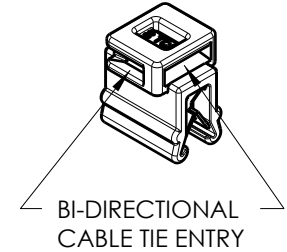
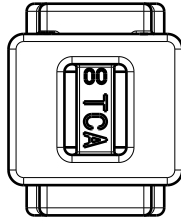

CLAMP FIT
FOR MATERIAL THICKNESS 1 - 3 mm

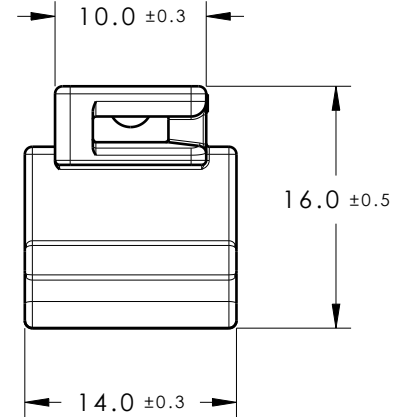

02.1

Material PA66HIRHSUV COLOR: BLACK	Units	millimeters	The copyright of this drawing is reserved by HellermannTyton. It is issued on condition that it is not reproduced, copied or disclosed to a third party, either wholly or in part, without the consent of HellermannTyton.	Drawn	AAC	06/19/14	Article/Type-No EC4	Scale	2:1	
	Tolerance defined on each dimension	Approved		SJA	06/19/14	Title EDGE CLILP 4		Project Number	14-0607	
		HellermannTyton North America Email: corp@htamericas.com Web: www.hellermann.tyton.com			Drawing-No		PRODUCTION : Phase	Format	AH	
					14-0607-001-CSU		Sheet	1/1		