

Product no.: 705512-150

Dimensions in mm and [inch]

A

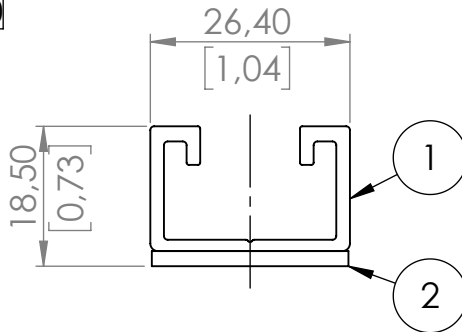

B

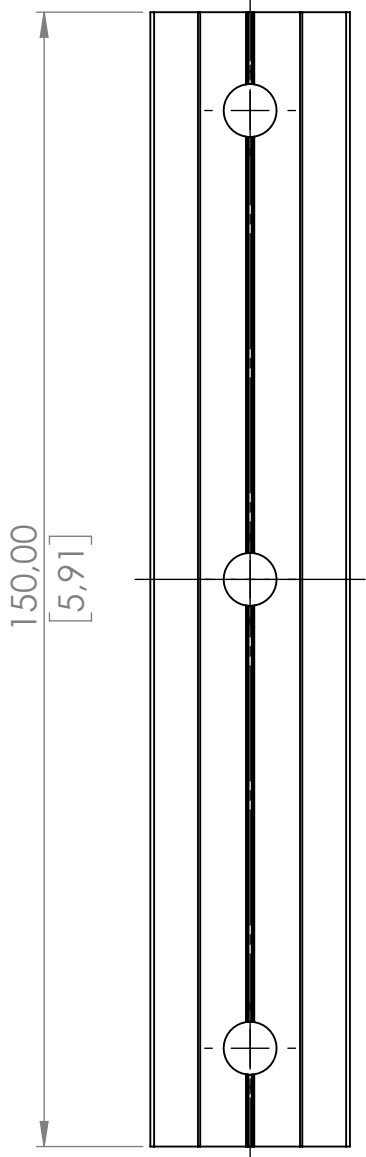

C

D

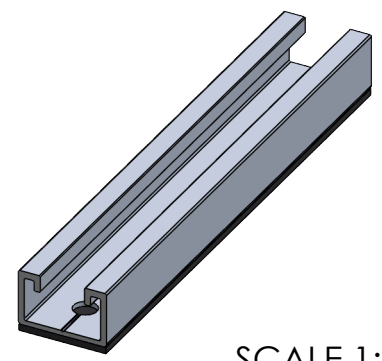

SCALE 1:2

E

Pos. No.	Pcs	Description	Material
1	1	Trapezoidal short rail L=150mm	EN AW-6063 T66 (HBW 75-80)
2	1	Protection pad 150x26x2mm	002005 - EPDM 2,0 mm

F

Standard: EN 1090 EXC1		Tolerances: DIN ISO 2768-mK		DIN ISO 128-30		Scale: 1:1 1:2		Weight: 0.06 kg											
						<input type="checkbox"/> xxxx Inspection dimensions		Material:											
				<table border="1"> <thead> <tr> <th></th> <th>Date</th> <th>Name</th> </tr> </thead> <tbody> <tr> <td>established</td> <td>27.05.2019</td> <td>mau</td> </tr> <tr> <td>approved</td> <td>24.06.2021</td> <td>mbu</td> </tr> <tr> <td>released</td> <td>24.06.2021</td> <td>nan</td> </tr> </tbody> </table>			Date	Name	established	27.05.2019	mau	approved	24.06.2021	mbu	released	24.06.2021	nan	Surface:	
	Date	Name																	
established	27.05.2019	mau																	
approved	24.06.2021	mbu																	
released	24.06.2021	nan																	
				AEROCOMPACT® www.aerocompact.com office@erocompact.com		Title: TS15		Index: C											
				Drawing No.: 705512-150		Trapezoidal short rail L=150mm		Page: 1											
Modification		Date		Name				A4											

F

Für diese Zeichnung behalten wir uns alle Rechte vor, auch für den Fall der Patenterteilung oder Gebrauchsmustereintragung. Ohne unsere vorherige, schriftliche Zustimmung darf diese Zeichnung weder vervielfältigt, noch Dritten zugänglich gemacht werden. Diese Zeichnung darf durch den Empfänger oder Dritte auch nicht in anderer Weise missbräuchlich verwendet werden. Zuwiderhandlungen verpflichten zu Schadensersatz und können rechtlich verfolgt werden. Wir reservieren uns alle Rechte an diesem Patentantrag. This drawing may neither be copied nor opened to a third party without our written agreement. It may also not be used improperly by the recipient or a third party in other ways. Contractors are obliged to compensate and can be prosecuted.